

User Manual and Kit Construction Notes

for the 2003 model of

THE FOUR LETTER WORD

kit order number code : FLWK3

Documentation release version 1.5

by Raymond Weisling, 22 July 2003

changes in revision 1.4:

- *Switchmode SHV power supply assimilated
(no longer available without SHV option)*
- *Parts list broken into two, for DUTU & CDTU*
- *Unneeded components removed from parts lists*
- *page 13 notice of release of firmware version 5-2.*

changes in this revision:

- *component values changed, R85 & R86, now 470k*
- *component values changed, C42 & C43, now 2.2 μ f
(values not critical, changed to agree with GeekKlok)*
- *C59 added to circuit, to lengthen reset period.*



THE FOUR LETTER WORD

SCOPE

This manual is intended for the Four Letter Word Kit, model FLWK3. This kit is a major update to the previous design sold as a kit, model FLWK. There are only a few similarities between these kits due to the extensive number of design changes that went into the new version.

HISTORY

The Four Letter Word was first produced by Raymond Weisling in 1973 and appeared in the June 1973 issue of Playboy magazine. Approximately 50 units were built between 1973 and 1975. In 1994 reconstruction of the piece was started using a small number of parts still on hand, enough for about four units, but for a variety of reasons it was sidetracked and somewhat forgotten. In 2001 several thousand of these jumbo Nixie tubes were found in a warehouse somewhere in New York. Their renewed availability prompted the completion of the work begun in 1994. The 2002 version was an intermediate step, combining aspects of the 1994 work with some new ideas. The 2003 model expanded on that. The latest version is an item that looks much like the original (depending on what kind of plastic case is used), but operationally is a far cry from the original. The technology employed in the reconstruction was simply not available in 1973. Word generation is vastly improved and several very entertaining word-game modes have been added. And to add a little practical functionality, it now also has a clock feature to show time.

OPERATION

When the unit is first turned on it will always display a greeting message: "FOUR LETTER WORD BY RAYMOND WEISLING" followed by the internal program version number, and then the word PLAY. At this point it will read and respond to the user settings on the DIP switch and begin displaying words. Due to internal and external indeterminate processes, the order and selection of words is always different. There should be no discernible patterns or sequences of words.

The indeterminate processes utilize pseudorandom number generators in the internal program and external oscillators that are read in parallel as a number at certain points. Because these oscillators use imprecise components and do not in any way operate synchronously with the program, the combination of the two results in considerable indeterminacy, which is often called randomness.

USER SETTINGS

An eight-position DIP switch is provided for setting different operational (performance) modes or user preferences. The switch is read at the beginning of each new word display cycle. In certain performance modes it may require some time before the word is finished displaying.

DIP switch position 1 = ON

When set to ON this selects the "**stick hangman**" mode. In this mode a word is chosen internally while the display is completely blank. Then individual segments that form the letters are turned on in an indeterminate sequence until the entire word is displayed in full.

DIP switch position 2 = ON

This selects the "**letter hangman**" mode. In this mode a word is chosen internally while the display is completely blank. Individual letters are turned on or enabled one at a time until the whole word is visible. The sequence of segments enabled is varied and indeterminate.

Both this and the "stick hangman" mode are especially entertaining to watch because you invariably try to guess the word before it completely appears. It is even more fun with a friend—it can become a game.

DIP switch position 3 = ON

This switch controls the **normal display mode** for words. When set to OFF a continuous stream of words is displayed at a fairly rapid speed. The actual period of time is somewhat indeterminate. When set to ON the same mode remains selected, but the changes are slower. This switch is primarily intended for adding the normal mode to a mixture of the other hangman modes, but also doubles as a speed control for the normal mode.

switch positions 1 or 2 or 3 = ON (any two or all three ON)

When more than one of the first three positions (1, 2 and 3) are ON, then the unit enters a **mixed display mode**. Words are arbitrarily shown in normal (all at once), letter hangman or stick hangman modes, depending on which switches of these three are set to ON. This is the only time that position 3 is functional to select its mode. It adds or subtracts the normal mode to one or both of the hangman modes. With these you have complete control of all three modes mixed any way that you wish.

DIP switch position 4 = ON

This switch enables the **low-priority clock time mode**. The clock has no battery backup, so each time electric power is turned off and then back on the clock must be set to the correct time. If the time has not been set, the clock mode is disabled regardless of the position of this switch. Once the user has set the time, with this switch set to ON, the time is displayed every 20 seconds (minimum), but only inserted in between two words in sequence. If a word change occurs before the 20 second limit is reached, the time display is deferred until the next word change. In the hangman modes this can end up being considerably longer than 20 seconds. The clock display is brief, and involves rapid flashing of the digits for about one second, so as to attract attention. Time is fleeting, catch it if you can.

DIP switch position 5 = ON

This switch enables the **high-priority clock mode**. In this mode both hangman modes are disabled. The words are displayed in the normal mode, alternating with the clock display, which appears without flashing. In both clock modes the seconds are shown by the underline segments, which represent a horizontal bar that starts at one segment (for 1 to 14 seconds) and extends to all four underlines (for 45 to 59 seconds); the first second of each minute has all four underline segments off.

When the high-priority clock mode is selected, switch positions 1 to 4 control the display speed for the clock and word display. Switches 1 and 2 control the duration of the word, and switches 3 and 4 control the duration of the clock display. The higher number switch of each pair has a greater weight in determining the duration.

If the clock has not been set since the last time power was turned on, then this mode will be inhibited, and Switches 1 to 4 will be ignored, even for mixed modes.

DIP switch position 6 and 7

These two positions control the appearance or nonappearance of impolite, vulgar or so-called "dirty" words. There are four possible settings of these two switches as follows:

SW7	SW6	resulting operation
OFF	OFF	unaltered or neutral operation (no bias, no censorship)
OFF	ON	vulgar words biased to appear once every 7–14 minutes
ON	OFF	vulgar words biased to appear once every 3–10 minutes
ON	ON	full censorship of vulgar words

The two selections to bias vulgar words to appear use indeterminacy in setting the interval of time between displays and which word is selected from a list of about 20 such words. When full censorship is selected, none of the words in the same list is allowed to be displayed.

The unaltered or neutral mode does not treat these words with any greater or lesser frequency.

DIP switch position 8 = ON

This switch enables a special mode that approximates, or roughly emulates, the operation of the 1973 version of the Four Letter Word. That version did not have a microcomputer or any memory chips—such technology was just appearing on the horizon and was prohibitively expensive. Instead, each nixie tube was arranged to only display ten letters out of the full alphabet. The ten letters chosen was adjusted to be different for each of the four tubes, based on analysis of English four-letter words. A separate counter for each tube rapidly sequenced through the ten letters, and periodically a snapshot of the counter value was grabbed and sent to the tube drivers, where the segments to make the letters were encoded by means of a diode matrix. Letter position 2 only had 8 letters since the 9th and 10th most frequent letters were much further down the frequency list and the highest two were especially frequent (so they were doubled). Thus 8000 different words could be displayed, of which only about 900 were real English words (a list of these still exists). In this mode the other DIP switch positions are ignored. The clock set and advance buttons can be used to decrease or increase the display speed (they have no effect on the clock time, which is not displayed, but continues to run internally).

If both DIP switches 7 and 8 are ON, then the 1973 emulation is not selected. Instead the Word Bank is inhibited and words only appear based on frequent letter pairs. (This is only available with Version 5-1 firmware or later.) See the section on firmware updates on page 12.

SETTING THE CLOCK

The clock hours and minutes are set by pressing one of two buttons. The SET button should be pressed once, at which time the Nixie tube display should show the hours. The ADV (advance) button is then clicked until the hours desired (1 to 12 or 0 to 23, depending on jumper WM) appears. Then press the SET button again to select the minutes digits, and then press the ADV button to move forward. The ADV button can be held down to quickly advance the digits. When the minute has been set, wait for that actual minute shown to begin, and then press the SET button to return to the word display. The seconds, as shown by the underline segments, are reset to zero when SET button exits the clock-setting operation.

CLOCK TIMEBASE

The clock timekeeping is based on the local electrical power grid frequency, which is 60 Hertz (Hz) in North America and a few other isolated places, and 50 Hz most everywhere else. Generally the power generation authorities maintain long-term stability of this frequency, but it might go slightly up and down over a shorter time period. The clock automatically adapts its internal operation for 50 or 60 Hz line frequency when first powered up.

WORD BANK

While the main goal of the 1973 version was to make words by random selection of letters that were weighted for English, the occurrence of real words was quite low. The 2002 version added a list of 1344 real words (limited by available memory), called a Word Bank. This was expanded further in this 2003 version by development of several new compression schemes. The present Word Bank holds over 2200 words in eight different internal database structures.

One of these structures, for example, has three of the four letters of a word explicitly encoded (in from three to five bits per character), while the fourth letter is indicated by a single bit in a field of bits that correspond to a set of letters (from 12 to 19 letters, never all 26, are in different sets).

For example, #EAR might be one entry, where # is a variable, bit-encoded field with bits set corresponding to the valid occurrence B, D, F, G, H, N, P, R, S, T, W and Y in real words. Thus one such database entry could take the place of separate database entries of these words: BEAR, DEAR, FEAR, GEAR, HEAR, NEAR, PEAR, REAR, TEAR, WEAR and YEAR, given that the software knows how to process the data correctly, and each of the variable letters is represented in the bit map field.

Four separate database structures having this basic form exist, for each of the four letters being the variable (#), namely #AAA, A#AA, AA#A and AAA# (where A represents any alphabetic character). These tables consume about 2100 bytes and contain over 1700 words, for an efficiency of around 1.25 bytes per four-letter word.

Words that do not fit into the above scheme, or whose variable field was too sparse to be efficient (e.g. #UOY, where only B is valid: BUOY) are encoded into several other tables using a different encoding process which uses two bytes per word. Some unusual words that would not fit into any other scheme are stored as 4 ASCII bytes.

WORD GENERATION BY RULES

Considerable research and analysis, spread thinly over a 30 year period ("I do have *other* interests": Weisling), went into developing the word generation scheme. To begin with, about 2500 English four-letter words were analyzed and three tables of letter-pair frequencies were derived. For example, the word BALE would have a count of one for the appearance of BA, AL and LE added to the tables for these pairs. For this version of FLW, short tables consisting of the most frequent letter pairs for each position were made. Each letter pair is encoded into one byte for storage.

Position 1 pairs include: AI, AR, BA, BE, BO, BR, BU, CA, CH, CL, CO, CR, CU, DA, DE, DI, DO, DR, DU, FA, FI, FL, FO, FR, FU, GA, GE, GI, GL, GO, GR, GU, etc.

Position 2 pairs include: AI, AK, AL, AM, AN, AP, AR, AS, AT, AV, EA, EE, EL, EM, EN, ER, ES, HA, HE, HI, HO, IC, ID, IK, IL, IN, IP, IS, IT, IV, LA, LE, LI, LL, LO, LU, NI, NO, NT, NU, etc.

Position 3 pairs include: AD, AL, AN, AR, AT, CE, CH, CK, DE, DS, ED, ES, ET, FE, FT, GA, GE, GY, ID, IL, IM, IN, IP, IR, IT, KA, KE, LD, LE, LL, LT, LY, MA, MB, ME, MP, ND, NE, NG, NK, etc.

This is another one of the word generating schemes, which can make real words and statistically-probable non-words. Such as BA+AM+MP = BAMP.

Further rule checking discards words with three consonants or vowels in a cluster, such as ODST, DRFY, or EAIS.

CIRCUIT DESCRIPTION

The heart of this device is the microcontroller, a Motorola MC68HC705C8A device that has 7684 bytes of program storage and 176 bytes of RAM. The program is stored in one-time programmable memory and is protected from copying or downloading. If you attempt to read the contents of the chip you will fail and might damage the part. The program is copyright by the author and represents an investment of considerable effort, both in recreational linguistic research, word database design and assembly language programming.

This 2003 model uses multiplexing to display characters on the nixie tubes. Only one tube at a time is turned on, but the rotation or sequencing occurs so quickly that you see a steady display of four characters. Multiplexing requires 15 transistors to turn on each segment (cathode), and four transistors to connect each tube's anode to the high-voltage power in sequence.

For those interested in the multiplexing details, nixie tubes are somewhat difficult to multiplex due to the high voltages switched, the large tube and printed circuit board geometries involved, which increase parasitic capacitance, and the relatively low current required to strike ionisation at a level that can be seen as a dim glow. The capacitance charges up to the potential, and if left charged when transistors switch off, can lead to ghosting and even reversed polarity (the anode mesh can itself glow at random pinpoints with glowing clouds surrounding them). The circuit in the FLW employs resistors from each cathode and each anode connected to a common intermediate voltage. Electronic circuit designers are familiar with pull-down and pull-up resistors. These are, in effect, pull-middle resistors. If there are any free-floating cathodes and anodes left charged after the transistors switch off, the charges are both brought to the same middle voltage, approximately half of the full high voltage. Not only is ghosting eliminated, it also appears to help silence acoustic buzzing noises that have been reported when multiplexing some types of nixie tubes.

Other circuit details that might puzzle the reader of our schematic must be considered in terms of functional options available with the FLW and also must consider that the same PCB is used for our GeekKlok product. That design needs additional components and interacts to a certain degree with the circuit of the FLW. Consequently some circuit and mechanical provisions to allow all options to peacefully coexist on the same board—though not all can be realised with components at the same time—were implemented.

RANDOMNESS AND INDETERMINACY

Microcomputer programmers can simulate randomness in software by creating and manipulating pseudorandom number generators. However, since microcomputers basically start operating the same program steps when power is applied, the result is that a pseudorandom generator always begins its operation from the same state, so the sequence of random numbers produced is always the same. Even if started at a different step ("seeded" with a different start value), the sequence from number to number is always the same. To produce an apparent degree of randomness requires an external source of imprecise and non-repeatable information not related or in any way synchronized to the internal program.

The Four Letter Word has a five-bit indeterminacy generator external to the microcontroller, consisting of five simple oscillators each with a different frequency, determined by external components (resistors and capacitors) of imprecise values. These oscillators operate at very approximately 100, 300, 450, 600 and 1400 Hz. Thus the relationship between individual oscillators is itself indeterminate, as each one oscillates at its own free-running frequency. When read as a parallel five-bit number, the value read is quite certain to be sufficiently unpredictable. The number read in on U2-31 through U2-36 is then used internally to set certain parameters or to cause the internal pseudorandom number generators to further scramble their data.

Randomness cannot be made more random, but pseudorandom generators can be made less determinate by altering their sequences or occasionally skipping over a step (shifting two times instead of once). There are four 16-bit non-linear feedback shift register pseudorandom sequencers, and each one is shifted at the same time, but based on the external five-bit value, one or more of the four generators is allowed to jump ahead to a different sequence, allowing the four different 65535-step sequences to slip out of phase with each other. Some parameters only require an 8-bit (or smaller) number, and these are taken, at different points in the program, from the high or low bytes of the 16-bit register, so this makes it seem like there are eight sources of pseudorandom numbers. With all of these factors combined, events are truly indeterminate. You may use the word "random" when describing it to visitors if you wish.

This indeterminacy is used to select letter pairs, Word Bank records, which mode is used next (when mixed modes are selected). It is also used to select hangman letter or segment appearance sequences and numerous other attributes of operation to produce a varied and interesting display. The operation of the pseudorandom generator coupled with the external oscillators has been carefully adjusted to give the highest degree of unpredictability possible, simply because words are so easy to remember and thus any repeating patterns would potentially be easy to discern.

CONSTRUCTION NOTES

PRINTED CIRCUIT BOARD

The PCB is a double-sided board made with flame-retardant FR-4 material. The copper circuit paths are solder plated and covered by a solder mask to help make soldering easier. Holes (except the largest ones) are all plated-through. To reduce radiated noise, improve reliability and lessen susceptibility to external noise, the surface is mostly covered with a copper ground plane in between tracks and component pads or lands.

NIXIE TUBE SOCKETS

The PCB has three holes for each tube pin. If you have original sockets, the socket terminals must have the very tip cut off, leaving a two-pronged fork-like shape. This also makes it easier to remove any old wires from the original equipment from which the sockets were removed. Straighten the pins as best you can. These go into the outer pair of holes. Getting 17 pairs of pins into the holes may be a little difficult, but this was the only way to allow use of this socket or the use of other pins if sockets are unavailable. The pins need to be bent outward slightly to align with the holes. You may cut off one of the two prongs leaving just half of the fork, or make one shorter; that will make it much easier to insert the pins. The Sylvania sockets, which have a large centre hole, have slightly larger and thicker pins than the Cinch sockets. The Cinch ones are marked with the name CINCH U.S.A. and also have a second set of 12 pin holes inside of the outer ring.

If you have no sockets, the larger holes for each pin are meant to receive pins made by Tyco (AMP) or Mill-MAX and available from Mouser, Digi-Key or Jan Wuesten (in Germany). These pins mount in the innermost holes, which are positioned exactly the same as the pins on the tubes. The large centre hole in the PCB is intended to allow the tube's vacuum tip-off seal to protrude below the surface. There may be a rare tube with the seal larger or offset from the centre (sloppy work), which would require a small amount of filing (of the PCB, er, *not the tube*). None like this were encountered among our stock, but we noted some coming close to interfering. Also note that socket pins used in place of a socket could have the pins improperly aligned with the tube's pins, inducing stress on the glass base, and leading to cracking and permanent damage to the tube. Be sure that all such pins are inserted properly and soldered in place while straight and uniform. Some builders have used a tube to hold the pins in place while soldering, which will work only if the tube's pins themselves are very straight. For Tyco pins the holes need to be drilled out with a US number 43 drill (0.089 inches, 2.25mm), which will still leave the copper plating intact.

MOUNTING

Ample mounting holes have been provided at the front corners and along the rear, plus holes are provided in between each Nixie socket. The intent is to use threaded standoffs in each hole to ensure stability and prevent drooping of the board, and prevent board damage if tubes are inserted or removed through careless rocking. Use any or all holes at your preference. You may mount the sockets on either side of the board. See the section on reverse (solder side mounting) of the sockets.

SWITCHES

The two buttons and DIP switch may be mounted on the either side of the board, to be activated from access holes in the top, bottom or rear of your case. The DIP switch and tactile switches may also be mounted externally, and for this there is a provision for a two-row 16-pin connector mounted in place of the DIP switch. The connector is assumed to be of the type that uses 0.025 inch square pins (0.63 mm) on 0.100 inch (2.54 mm) centres, with either discrete wire or ribbon cable. Refer to the schematic diagram for pin numbers and functions.

OPTIONS

The PCB incorporates many features to maximize your enjoyment and allow customisation to match your needs and taste.

1. Nixie Location. Sockets are normally mounted on the component side of the board. However, there are occasions when it is better to mount the sockets on the solder side of the board. When the latter mounting is required the board is intended to be reversed with the components facing down. This reduces the mechanical interference from components, allowing the use of cases with nearly no gap between the PCB plane and the inside of the case. Such case designs usually have the tubes exposed through holes in the top of the case. Choosing which side to mount sockets on also affects the position of jumpers and some component locations. See the special section on Reversed Tube Mounting.

2. Serial Input with RS-232. The display of words is automatic and continuous in normal operation, but if the PCB is loaded with a MAX232 (or equivalent) part at U95, the serial input port is always active and ready to override the automatic display. The automatic display is stopped when a carriage return is sent to the unit. If any displayable characters are sent prior to the carriage return the last four will be displayed. To resume normal automatic word display, an escape character must be sent. (With just a carriage return and escape, the display can be enabled and

disabled for extended periods via the serial port.) This option is at the user's discretion. None of these components is included in the kit. The user must supply a RS-232 connector, wiring, U95 (MAX232), four capacitors (C90, C91, C92 and C93), and resistor R89.

Each time a string of characters is received, followed by a carriage return, the last four characters will be displayed. If more than four alphanumeric characters are received, the earlier (extra) ones are retransmitted out of the serial port as each new one is received. The carriage return, or escape character, is also sent out the serial port immediately when received. This allows multiple PCBs to be ganged together to display longer messages, by connecting the serial output of the first to the serial input of the second, and so on. Each unit after the first would receive its serial input from the "upstream" PCB and each would "steal" the last four characters it received for its display, passing on the earlier ones to the next unit in the daisy chain. Thus the chain is loaded from the right-most unit and letters propagate upward to the left. Connection between units, if mounted in the same case, can be direct thus bypassing the RS-232 levels. Only the first unit would require the MAX232 level translator on the serial input.

The character set is reduced from full ASCII. Letters A–Z, numbers 0–9 and the following punctuation characters are allowed.

	space
\$	dollar sign
"	double quote
'	single quote
()	left and right parenthesis
*	asterisk
–	minus or hyphen
/	slash (or virgule)
–	underline (alone, not as an attribute to another character)

All other characters are converted to the space character, including any with the high bit set (bit 7).

Serial format is EIA-RS-232A, 2400 baud, 8 bit length, no parity, one stop bit (8N1). This can not be changed. The PCBs are made to allow ganging multiple boards with no difference in the gap between tubes. A special version of internal firmware with no clock or four-letter word features and simplified PCB loading is planned at a substantially reduced price to allow very long displays to be made. Please contact Zetalink for more information.

One additional special RS-232 level input is provided. This is marked as DA on the board. This signal can be used to disable the nixie display tubes. It is merely a level and is not a serial data line. Its association with the RS-232 circuit is one of convenience and safety, because U95 provides some degree of protection for the microcomputer. If U95 is installed, no connection to this input will result in a normal display. Connecting this input to a more positive voltage, relative to the GND signal on the adjacent hole, will blank the nixie display. The response speed is very rapid.

If the RS-232 option is not used, load R100 and a jumper at U94 between pins 10 and 14.

3. Colon Option. There is a driver transistor intended for the addition of a pair of neon glow lamps as colons for the clock mode. Since the characteristics of these are not known, anyone wishing to add colons to separate hours and minutes should determine the actual value of resistor R83, which may need to be changed. The schematic shows two neon lamps in series, but the user may wish to place them in parallel, each with its own resistor. Connection to the drive is via a pad and hole marked COL-OPT, located immediately "north" of U2. The other COL-OPT point is on the high-voltage point, and is located in the "northeast" corner of the board; this connection may also be taken from one side of R28 or from pin 1 of J91.

Notice of change. Serial input with RF at 433 MHz. This option has been withdrawn for technical reasons. We overlooked the fine print on the data sheet for the RF receiver module. It is not designed to work the way that was intended in this application due to its primary design as a PWM receiver. Certain ASCII codes will not receive properly in NRZ coding due to capacitive coupling of the data slicer in the module. We will be seeking a substitute solution in the future. Note that we always stated in the documentation that operation with this RF module was not guaranteed. When we finally had an opportunity to test it we discovered that it will not work. We regret any inconvenience that it may have caused.

POWER SUPPLY

The FLW operates from an external power source of 12 volts AC, and requires 300 mA current. Thus we recommend a supply with a rating of 12 volts at 350 mA minimum. The ideal power supply would be a "wall wart" type with full agency approvals for your location, e.g., UL, CSA, TUV, CE, etc. The voltage from the transformer should not exceed 14 volts.

In the USA, Digi-Key stocks several appropriate "wall wart" power packs, other suppliers have similar offerings:

Digi-Key no. MT7102-ND	(Tamura 820A0061-03)	12.0VAC, 1000 mA
Digi-Key no. T611-ND	(CUI Stack DPA120040-S/T-SZ)	12.0VAC, 400 mA
Digi-Key no. T607-P1P-ND	(CUI Stack DPA120060-P1P)	12.0VAC, 600 mA

The switchmode power supply consists of a small number of parts that will generate about 170 volts from the DC that is rectified by D5 to D8 from the external AC transformer. This circuit is based on a MAX771 or MAX1771 IC (Y71), an inductor (K71), a special ultrafast recovery diode (E71), a power FET (F71) and a few other resistors and capacitors. C42 and C43 are used to hold the +85 volt (HV/2) line at a constant level.

Resistor R91 may be supplied with a different value, and without R91T. The optimum value is 0.33 ohms. This sets the upper current limit of the power supply, protecting it against short-circuits and overloads.

POWER SWITCH

There is no power switch included, and since the unit is a clock with no battery backup provision, it must be operated continuously if the clock option is used. If the clock function is not used, the user may completely cut power to the unit in order to increase Nixie tube lifetime and reduce electrical power consumption. The clock digits will never appear, even if the DIP switch is set to select the clock mode, if the time has not been set since the power was first applied. This prevents a meaningless and incorrect time display after a power failure.

If the RS-232 option is added, consisting of U95, C90, C91, C92, C93 and resistor R89, then the DA connection can be used to disable the display. A switch can be connected between DA and +5 volts, such that when the switch is closed the display will blank. (No convenient pad for +5 volts is provided; a good place to get this is from the hole on the "east" end of L96, near to U96.)

With the RS-232 port, a remote serial device can also blank the display by sending a single carriage return (0x0D). To reactivate the display, send an escape character (0x1B).

ERRATA — PCB ERRORS

The following minor errors or omissions exist on the PCB marked ZFLW2391 (no revision).

1. Error. C59 is a late addition, and has no mounting holes. It may be added to the solder side of the PCB between U2 pin 1 and the grounded emitter load of Q18 (that is the one closest to U2 pin 5). Omitting this capacitor is generally not a problem, but in rare cases the unit will not properly recognise 60 Hz power and will only count 50 cycles to make a second, so the clock will run fast. The capacitor lengthens the reset start-up period to allow the crystal more time to become stable.
2. The polarity for G71 is not marked. The plus lead is on the "north" (close to the marking for C46).
3. The polarity for N71 is also not marked. The plus lead is on the "east" (closest to C72).
4. If the RS-232 option is not used, resistor R100 must be installed between holes for U95-12 (marked "R") and U95-16, and a jumper wire is required from U94-10 and U94-14. If the RS-232 option is used, omit R100 and the jumper at U94.
5. The solder mask for the top and bottom was erroneously reversed, so that voltage regulator U1 has a bare area on the wrong side. The regulator actually operates so cool that it needs no heat sink or physical mounting to the PCB, but a hole has been provided for it (out of habit).

PARTS LIST

For CUTU Mounting option

Some parts are also marked on the PCB with a single character, to facilitate assembly of identical parts. These markings are shown in the "PCB" column, adjacent to the reference designation for the parts.

<i>description</i>	<i>qty</i>	<i>value/identifier</i>	<i>PCB</i>	<i>reference designation</i>	<i>notes or marking</i>
cap alum.	1	1000µf or 470µf/25v	—	C40	
cap alum.	2	2.2µf/160v	—	C42 C43	
cap ceramic	2	22 pf	—	C44 C45.....	.20 or 22
cap mylar	1	33 nf	—	C46	333
cap alum	1	4.7 µf/250v		G71	
cap alum	1	220µf/16v		N71	
cap mono.	15	100nf	—	C47...C56 C59 C61 C62 C71 C72.....	104
diode, 1A	4	1N4007	—	D5 D6 D7 D8.....	
diode, sig.	10	1N4148	—	D90...D99.....	glass
diode, ult. fast	1	600V, 1A, 75 ns		E71	MUR1100E or UF1005
resistor	1	10M	—	R87	brn-blk-blu
resistor	2	27k	[A]	R40 R44*.....	red-vio-orn
resistor	3	18k	[K]	R31* R34 R45	brn-gry-orn
resistor	3	47k	—	R4 R8 R9	yel-vio-orn
resistor	30	33k	[3]‡	R1 R2 R5 R10...R25 R72...R74 R81 R82 R84 R88 R100 <u>R71</u>	orn-orn-orn
resistor	15	1.5M	[9]	R51...R59 R60 R61 R62 R63 R64 R65.....	brn-grn-grn
resistor	7	22k	[B]	R6 R32 R33 R35 R36 R38 R42	red-red-orn
resistor	5	100k	[1]	R3 R67 R68 R69 <u>R66</u>	brn-blk-yel
resistor	4	2.2k	[H]	R27 R28 R29 <u>R26</u>	red-red-red
resistor	2	10k	—	R7 R83 R94	brn-blk-orn
resistor	4	20k	[E]	R37 R39 R41 R43	red-blk-orn
resistor	6	470k	[2]	R47 R48 R49 <u>R46</u> R85 R86	yel-vio-yel
resistor	5	100	—	R95 R96 R97 <u>R98</u> R99.....	brn-blk-brn
resistor	1	0.5R		R91	may supply 0.33R (0.33 ohms) instead
resistor	1	1R		R91T	parallel with R91 to trim to about 0.33 ohms
resistor	1	1.2M		R93	
transistor	4	MPSA92	—	Q22 Q23 Q24 <u>Q21</u>	
transistor	21	MPSA42	—	Q1...Q10 Q11...Q15 Q17...Q19 Q26 <u>Q16</u>	(+1 extra)
power FET	1	IRF830/840		F71	
crystal	1	4.0 MHz	—	Y81	
DIP sw	1	8-position		S82	
inductor	1	220 µH		K71	
IC socket	1	40-pin		(U2)	
IC	1	68HC705C8A		U2	
IC	1	74HC14		U3.....	(user-supplied socket optional)
IC	1	7805		U1	
IC	1	MAX771C		Y71.....	must not be put into socket
click sw	2	12mm		S83 S84	
jumper wire	11	CUTU option		W1...W9 W11 W12	(See section on Reverse Tube Mounting)
jumper wire	none			WL	not used for CUTU mounting, leave open
jumper wire	2			WT, also at U94	
jumper wire	(?)	24-h option		WM	(install for 24-hour clock display)
Nixie Tube	4	B-7971		V91...V94.....	
Tube Socket	4			for V91...V94.....	if using vintage sockets, or:
Socket Pins	68	optional		Tyco-AMP no. 1-380758-0.....	see Note 1, or:
Socket Pins	68	optional		Mill-MAX no. 0331-0-15-01-18-27-10-0.....	see Note 2

‡ not all components of this value have an identifier mark (single character) inside the rectangle for the component.

* R31 and R44 values have been adjusted for CUTU mounting.

Parts with underbar or overbar are subject to top or bottom tube mounting. See section on Reverse Tube Mounting.

Note 1: Digi-Key order no. A29073-ND, Jan Wuesten (www.askjanfirst.com) order no. FAS900

Note 2: Digi-Key order no. ED5019-ND, Mouser order no. 575-033100, Jan Wuesten (www.askjanfirst.com) order no. FAS901

PARTS LIST

For CDTU Mounting option

Some parts are also marked on the PCB with a single character, to facilitate assembly of identical parts. These markings are shown in the "PCB" column, adjacent to the reference designation for the parts.

<i>description</i>	<i>qty</i>	<i>value/identifier</i>	<i>PCB</i>	<i>reference designation</i>	<i>notes or marking</i>
cap alum.	1	1000µf or 470µf/25v	—	C40	
cap alum.	2	2.2µf/160v	—	C42 C43	
cap ceramic	2	22 pf	—	C44 C4520 or 22
cap mylar	1	33 nf	—	C46333
cap alum	1	4.7 µf/250v		G71	
cap alum	1	220µf/16v		N71
cap mono.	15	100nf	—	C47...C56 C59 C61 C62 C71 C72104
diode, 1A	4	1N4007	—	D5 D6 D7 D8
diode, ult. fast	1	600V, 1A, 75 ns		E71MUR1100E or UF1005
diode, sig.	10	1N4148	—	D90...D99glass
resistor	1	10M	—	R87brn-blk-blu
resistor	2	27k	[A]	R40 R31*red-vio-orn
resistor	3	18k	[K]	R44* R34 R45brn-gry-orn
resistor	3	47k	—	R4 R8 R9yel-vio-orn
resistor	30	33k	[3]‡	R1 R2 R5 R10...R25 R72...R74 R81 R82 R84 R88 R100 <u>R80</u>orn-orn-orn
resistor	15	1.5M	[9]	R51...R59 R60 R61 R62 R63 R64 R65brn-grn-grn
resistor	7	22k	[B]	R6 R32 R33 R35 <u>R36</u> R38 R42red-red-orn
resistor	5	100k	[1]	R3 R67 R68 <u>R69</u> <u>R70</u>brn-blk-yel
resistor	4	2.2k	[H]	R27 R28 R29 R30red-red-red
resistor	2	10k	—	R7 R83 R94brn-blk-orn
resistor	4	20k	[E]	R37 R39 R41 <u>R43</u>red-blk-orn
resistor	6	470k	[2]	R47 R48 R49 <u>R60</u> R85 R86yel-vio-yel
resistor	5	100	—	R95 R96 R97 R98 R99brn-blk-brn
resistor	1	0.5R		R91may supply 0.33R (0.33 ohms) instead
resistor	1	1R		R91Tparallel with R91 to trim to about 0.33 ohms
resistor	1	1.2M		R93	
transistor	4	MPSA92	—	Q22 Q23 Q24 <u>Q25</u>	
transistor	21	MPSA42	—	Q1...Q10 Q11...Q15 Q17...Q19 Q26 <u>Q20</u>(+1 extra)
power FET	1	IRF830/840		F71	
crystal	1	4.0 MHz	—	Y81	
inductor	1	220 µH		K71	
DIP sw	1	8-position		S82	
IC socket	1	40-pin		(U2)	
IC	1	68HC705C8A		U2	
IC	1	74HC14		U3(user-supplied socket optional)
IC	1	7805		U1	
IC	1	MAX771C		Y71 must not be put into socket
click sw	2	12mm		S83 S84	
jumper wire	11	CDTU option		X1...X11(See section on Reverse Tube Mounting)
jumper wire	1	CDTU option		WL(See section on Reverse Tube Mounting)
jumper wire	2			WT, also at U94	
jumper wire	(?)	24-h option		WM(install for 24-hour clock display)
Nixie Tube	4	B-7971		V91...V94
Tube Socket	4			if using vintage sockets, or:
Socket Pins	68	optional		Tyco-AMP no. 1-380758-0see Note 1, or:
Socket Pins	68	optional		Mill-MAX no. 0331-0-15-01-18-27-10-0see Note 2

‡ not all components of this value have an identifier mark (single character) inside the rectangle for the component.

* R31 and R44 values have been adjusted for CDTU mounting.

Parts with underbar or overbar are subject to top or bottom tube mounting. See section on Reverse Tube Mounting.

Note 1: Digi-Key order no. A29073-ND, Jan Wuesten (www.askjanfirst.com) order no. FAS900

Note 2: Digi-Key order no. ED5019-ND, Mouser order no. 575-033100, Jan Wuesten (www.askjanfirst.com) order no. FAS901

REVERSED TUBE MOUNTING

The printed circuit board was designed to allow the option of mounting the tubes (and of course the sockets) on either the component side or on the opposite side. When they are mounted on the “bottom” side, the whole board must be reversed when using it so that the tubes project upwards and the other components hang downwards from the PCB. This can be abbreviated to CDTU, Components Down, Tubes Up. The normal mounting is thus CUTU, Components Up, Tubes Up.

With reversed CDTU mounting there will be no mechanical interference between components and the top of a low-profile case. Such a case is usually intended to show off the tubes, projecting out from the case in plain view.

To build the kit for CDTU mounting, please refer to the separate parts list and assembly diagram. The all-important firmware control over the operation is determined by jumper WL. This selects between normal and reverse segment decoding and anode switching sequences. The second page of the schematic shows the pin numbers resulting from both mounting options. The signal names for the cathodes are only valid for CUTU. The anode names, however, refer to CUTU, followed by an underline, then the CDTU anode number.

When the tubes are on the opposite side, the tube pin for the anode changes position with one of the cathode pins (and the same is true for another internal connection pin that was used during manufacture to boil off a small amount of mercury). To properly steer the correct anode and cathode functions to the correct pin, a group of numbered jumpers is provided, located between or near the tubes. Jumpers marked W (W1 to W12) are to be installed for CUTU mounting. Jumpers marked X (X1 to X11) are to be installed for CDTU mounting. Note that there is no jumper number W11.

Additionally, anode driver components R46, R66, Q16, R71, Q21 and R26 are only mounted for CUTU, and are left open for CDTU.

For CDTU mounting, R30, R50, Q25, R70, Q20 and R80 are loaded; they are left open for CUTU. These components are merely different locations for R46, R66, Q16, R71, Q21 and R26, and retain the same values for each function. Thus these changes to the parts list are required:

<i>CUTU</i>		<i>CDTU</i>	<i>value</i>	<i>PCB</i>
R66	=	R70	100k	[1]
R46	=	R60	470k	[2]
R71	=	R80	33k	[3]
R26	=	R30	2.2k	[H]
Q16	=	Q20	MPSA42	
Q21	=	Q25	MPSA92	

Also note that R31 and R44 values are reversed if comparing the two parts lists. The markings on the board for these two resistors have an asterisk (*) to alert you to this change. These values control the correct amount of cathode current to only two out of 15 cathodes that change when the tubes are inverted. All other resistors remain the same because, though the drivers go to different cathodes, by luck the physical length of the cathodes is no different for both mounting options. Only R31 and R44 must be adjusted. (It took quite a while to work all of these details out.)

When sockets are mounted on the top, note that pins 1 and 17 are marked on the top, and that the hole between 1 and 17 is not used. If individual socket pins are used, it is a good idea to fill these holes with solder so that the tubes can not be inadvertently inserted (rotated) to some other orientation.

When sockets are mounted on the reverse side (CDTU), likewise pin 1 and pin 17 are marked on that side, with the unused pin not to be used. The correct pads are encircled to further assist the builder. Again, the unused holes in the extra pad should be filled with solder if socket pins are used. In both cases pin 1 is facing to the front.

The position of the numbered W or X jumpers must be correct to avoid possible component damage. Jumper WL, which selects between the two modes, can be installed incorrectly with no harm, except that the characters will be garbled since the wrong segments are being decoded from the characters. If this symptom is observed, check the correct position of WL.

One more note: When CDTU mounting is chosen, the segment test, activated by pressing both SET and ADV buttons when applying power, will not sequence the segments in the same order as for CUTU. With CUTU the segments sequence according to the segment number as published by Burroughs. For CDTU the order is necessarily different. The CDTU segment test sequence is: 14, 6, 5, 4, 3, 2, 9, 8, 7, 10, 13, 12, 11, 1, 15 (underline).

FAQ

Q. Not all of the parts are used. there are empty holes for other parts. What are these for?

A. A number of parts that are not loaded for the FLW are intended for the GeekKlok (GKK), a clock-only variation of this same basic circuit. U94 is a real-time clock that has its own crystal oscillator and battery (the battery sits where U95 goes—the outline of the battery holder is marked in a broken line). J91 can connect to a simple auxiliary two-digit nixie display to add seconds to the GKK. U93 (located between R76 and R92), and other nearby parts, is a different power-line reference circuit that supplies missing pulses during very brief power line drops.

Q. How can I change the speed of the 1973 Four Letter Word emulation (DIP switch 8 = ON)?

A. Use the SET and ADV buttons to change the speed. Pressing these buttons in this mode will not affect the time.

Q. What letters are used in the 1973 emulation mode?

A. In the first position: B, C, D, F, H, L, P, R, S and T. In the second position: A, E, H, I, L, O, R and U. In the third position: A, C, E, I, L, N, O, R, S and T. And in the fourth position: D, E, K, L, N, P, R, S, T and Y. These were the most frequently occurring letters for each position out of a large sample of English words. If all 26 letters had been allowed, there would be almost a half million combinations, while there are at most 3000 English four-letter words. By limiting the letters about 900 words out of 8000 combinations can be made (11.3%). That was the extent of rule-based word generation available in 1973.

Q. When the room is extremely quiet I can very faintly hear a hum or buzz from the display. What is this?

A. Nixie tubes involve a lot of nasty physics at the molecular level. The ionized gas near each cathode heats up, though not enough to matter relative to the total volume of gas in the tube. And there are electrostatic forces at play when the voltages are changed. These contribute to a very slight degree of acoustical noise emitted from the tubes when they are switched on and off (swept) 125 times each second. Some nixie tubes may be louder due to internal differences in construction (looseness of parts). We were unable to produce any noticeable sounds with a sample of nixie tubes. In a very quiet room we still must get within two centimeters (an inch) of the tubes before anything at all could be heard. The multiplexing circuit that we developed seems to contribute to quietness.

Q. Why isn't there a way to have only the clock show?

A. This is a word sculpture, by design. It is intended to entertain by surprising the viewer with a large number of words, and to entice him/her to enjoy the challenge of trying to guess the word (especially when one of the hangman modes is selected). It just can't be just a clock—it wouldn't be **The Four Letter Word**. For those interested in just a clock, we have the **GeekKlok**. But it is also not just a clock, because it has an enormous number of user options, preferences and settings. But at its minimum it can just display time, all of the time, just like this can display just words, all of the time, at the simplest level.

Q. Are there any built-in tests?

A. Yes, the segments of the Nixie tubes can be tested. Disconnect power to the unit, wait 20 seconds or so, then press both SET and ADV buttons and hold them down while applying power to the unit. All four tubes will show the same segment lit. To step to other segments, press the ADV button. The SET button has no function. To stop the test, again disconnect power from the unit. The DIP switches quite clearly control different modes, so these can be tested by selecting the different modes of operation. Note that the clock must have been set since power was first applied in order for the clock modes to show time. The biased vulgar word settings can be turned on, and usually one of the words will come on immediately; you will have to wait up to ten minutes to test the other one, or simply cycle the power. If each censor/vulgar switch works by itself, then both set to on for full censorship will work, though there is no way to test this since these words don't appear that often, and if censorship is working, you will never see the vulgar word. Trust us, it works. If you still see a word that is offensive, your sensitivities are obviously not the same as ours.

TROUBLESHOOTING

Usually the Four Letter Word will play when it is first started up. The "hello" message should run and then words should appear. If this doesn't occur, then troubleshooting is required. The basic requirements are a multimeter, but an oscilloscope is generally the preferred instrument for serious troubleshooting.

Some problems are shown below.

1. Unit is totally blank. Check to see if there is about 10 to 14 volts at the cathode of D6 or D7. Then check for 5 volts on pin 40 of U2 or pin 14 of U3. If these are OK, then check the high voltage. R9 has a marking on the PCB showing which lead should be at about 170 volts. In addition, if the RS-232 option is not installed, be sure that there is a jumper at U94 from pins 10 to 14.
2. Units shows only the first word of the hello message: "FOUR" and then it stops. Check to see if jumper WT might have been forgotten (it is near pin 1 of U3). Check the value of R85 and R86 (must be the same) and C52. This symptom indicates that the 50 or 60 Hz power line pulses are not getting to the microcontroller (U2). The circuit path involves R88, R84, and U3 (to square-up the sinusoidal signal).
3. Some segments are missing in one or more tubes (but not all tubes). Using the segment test (press both setting buttons when applying power), cycle through to see if all segments are showing. A segment missing in some of the tubes indicates a bad socket connection. Check the socket. Occasionally vintage sockets do not grip the pin properly. It may be necessary to use a pointed tool to bend the socket clip inwards just a bit. If the affected segment is number 4 or 10, check the W or X jumpers (one might be missing).
4. A segment is dead in all tubes. This indicates that the driver transistor is not turning on. The transistor could be defective, not soldered correctly or its base resistor might be the wrong value.
5. A segment is always on in all tubes (and probably brighter than it should be). This indicates that the cathode for that segment is permanently shorted to ground. Inspect all solder joints to be sure that no solder bridges to other components or to the ground plane exists. The driver transistor might be shorted or defective. One can't rule out a copper whisker from a track or pad to the ground plane, which is a PCB manufacturing defect.
6. One tube never shows anything, but all others are working OK. Check to make sure that the four anode drivers (Q22, Q23, Q24, Q21/Q25) are type MPSA92 and not MPSA42. Also check the intermediate transistors that precede these (Q17, Q18, Q19, Q16/Q20), or related resistors.
7. One tube is brighter than the others and the character includes segments from other positions. This indicates that one anode is always on. The MPSA92 might be shorted or the base drive from its MPSA42 might be shorted to ground.
8. One or more DIP switch options/modes do not work. If the modes are related to the clock, be sure that the clock has been set since power was applied. Aside from this oversight, if a switch position is not working, check to be sure diodes D90 to D99 are correctly installed. With power turned off, be check the switch itself to see if that it is zero ohms when set to ON. For switches that are ON, the oscillators of U3 are stopped whenever the switch is read; this can be seen on a storage (digital) oscilloscope.

FIRMWARE REVISIONS

Version 5'0. First release (30 March 2003). Full functionality.

Version 5-1. Minor update (13 April 2003). Small problem fixed and improvements made as follows:

- a. BUG. Very small flicker when words changed; reading DIP switch killed anode drive until next 2 millisecond timer event, when next anode in sequence is enabled; fixed.
- b. IMPROVEMENT. Initial speed of 1973 Four Letter Word box emulation was too fast and the display speed limits when using the buttons were too fast at both ends of the range; new initial value is slower; new upper and lower limits for button-based speed control now slower.
- c. ADDITION. It is now possible to defeat the Word Bank and only use words generated by the selected high-frequency letter pair rules. **DIP switch 7 and 8 must be ON** to select this. Normal and hangman modes still function as usual, and both clock modes are also unaffected. With this setting the 1973 emulation mode is changed to letter-pair rule generation. The censorship mode is also affected, with the remapping of DIP switch 7 to this function. When DIP switch 8 is off, position 7 returns to its normal censorship role.
- d. CHANGE. The start-up title "hello" message cannot now be bypassed by pressing the SET or ADV buttons.

Version 5-2. Minor update (20 May 2003). Very obscure error in letter pair rule word generation discovered and corrected, where words occasionally ended in TB (e.g., DATB), where they should have ended in UB (DAUB). This was more easily noticed due to added mode in Version 5-1 (DIP switch 7 & 8 = ON). It was allowed to play for hours this way.

The unnumbered pages that follow show component locations for CUTU and CDTU mounting options, other options, schematics, and physical dimensions of the PCB.

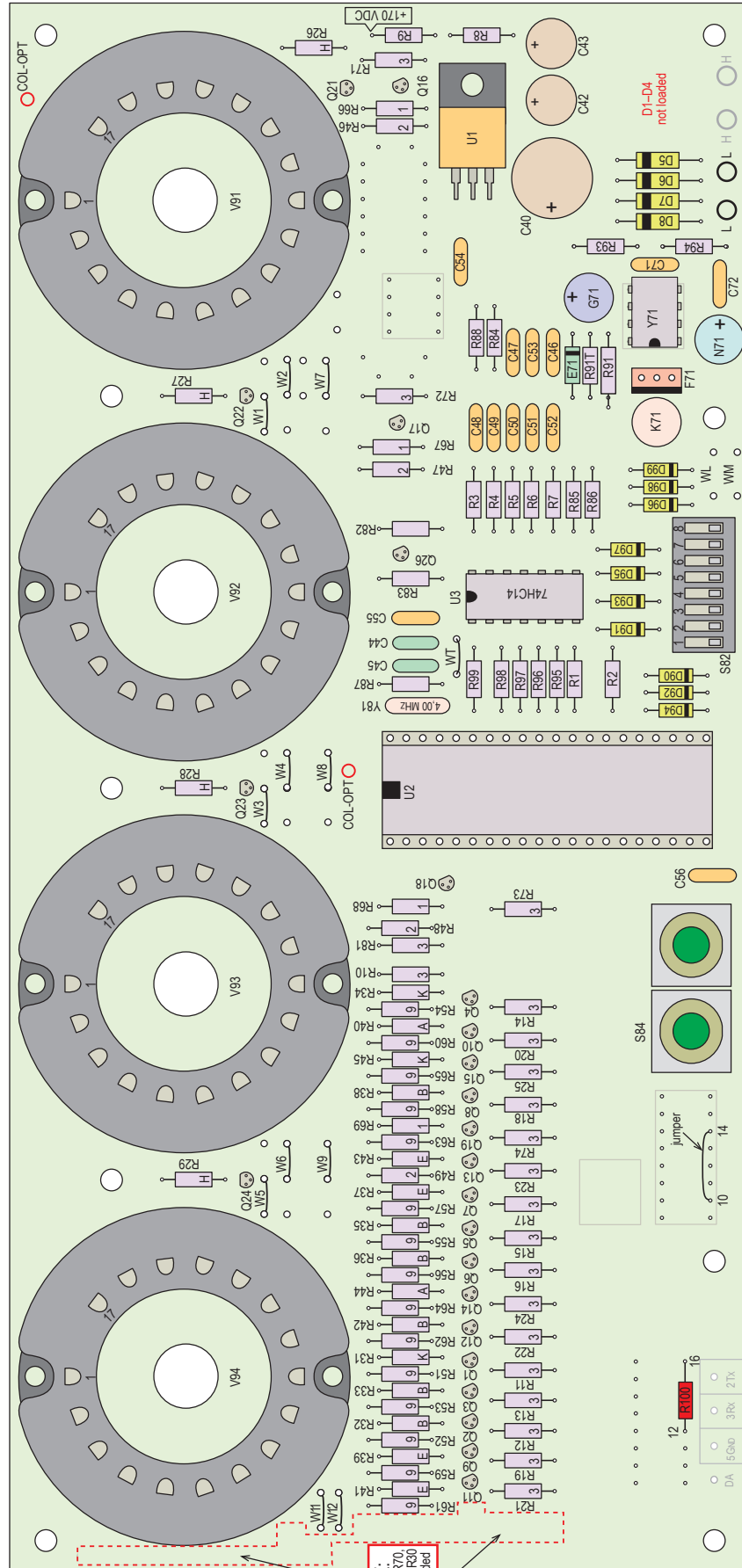

NOTE:
R80, C20, R70,
C25, R50 & R30
are not loaded

Normal Nixie Mounting—CUTU

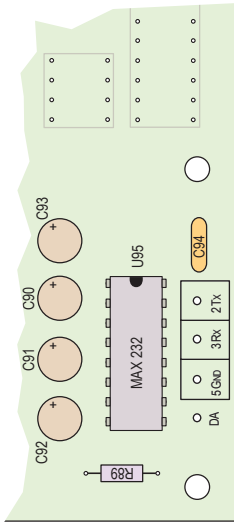

Serial RS-232 Input Option

detail of affected components only

Components supplied by user.

Previous option for switchmode power supply is now included in main drawings and parts lists.

Option for RF serial input module has been withdrawn.

PCB Mounting
 for PCB ZFLW2391 Revision — (no rev marking)
 Used in Four Letter Word, GeekKlok, Four Character Display

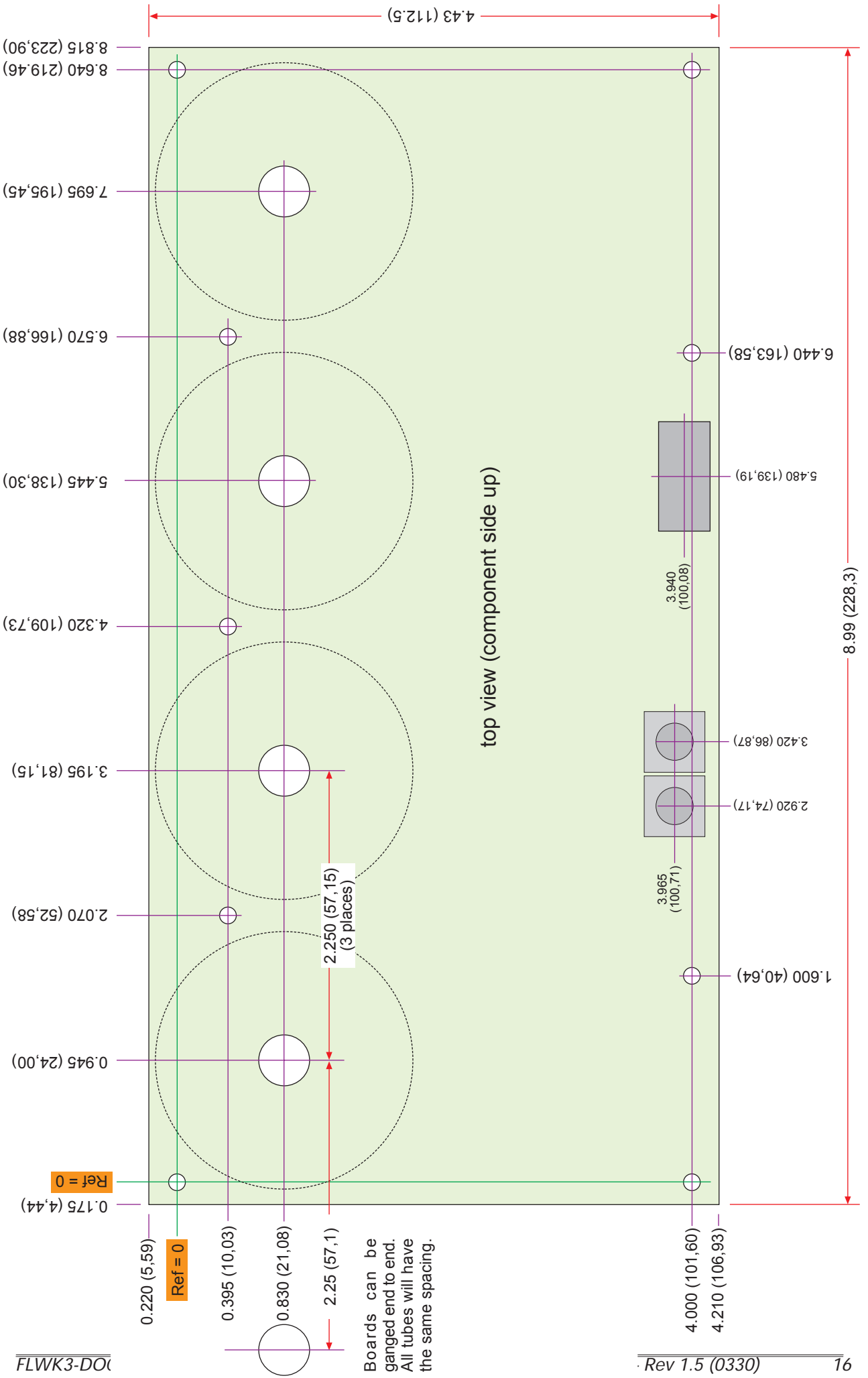

Boards can be ganged end to end. All tubes will have the same spacing.

Four Letter Word Model FLW-2003 (kit order number FLWK3)

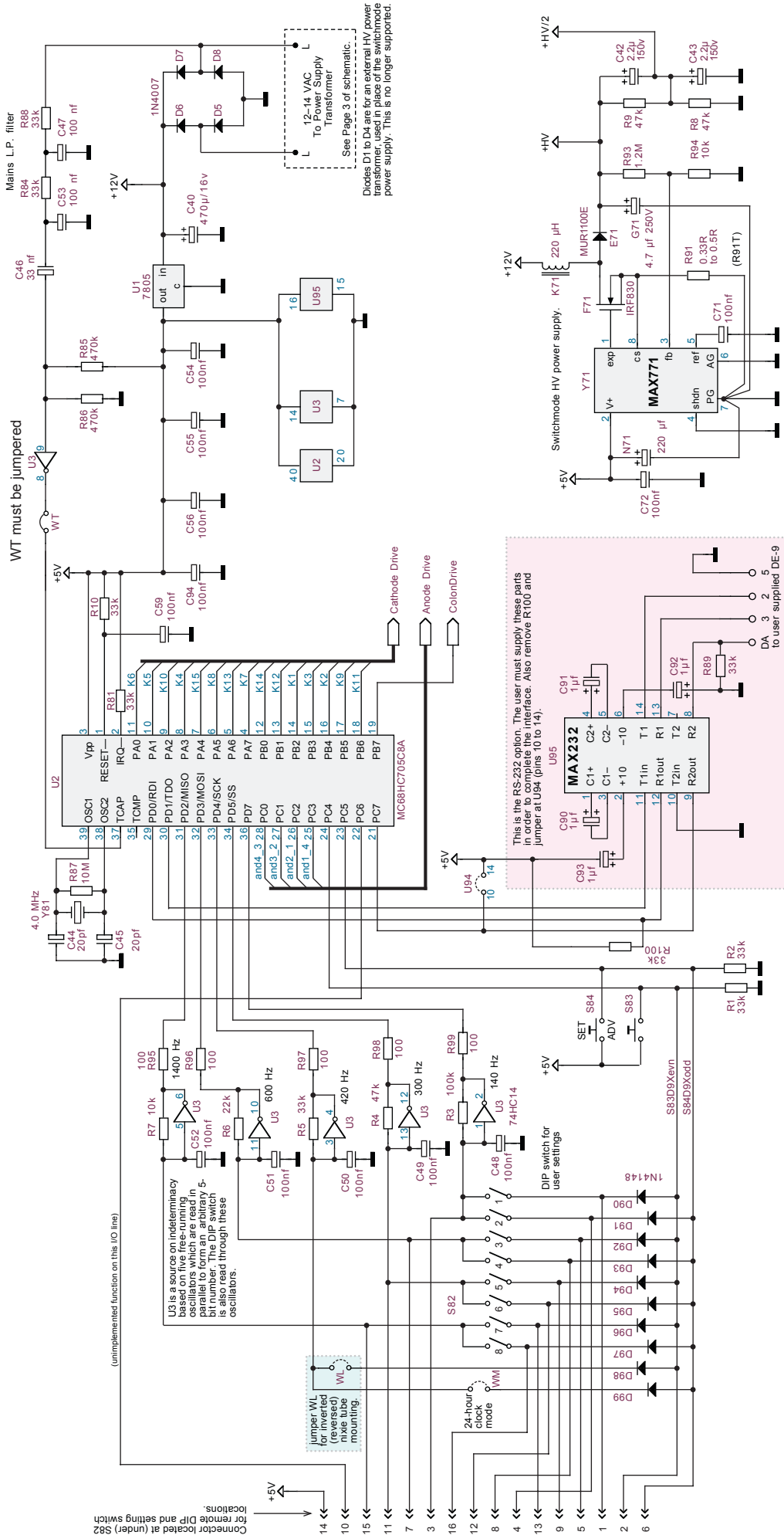

Connector located at (under) S82 for remote DIP and setting switch locations.

Jumper WT (reversed) for inverted (reversed) mounting.

24-hour clock mode WMM

DIP switch for user settings

This is the RS-232 option. The user must supply these parts for order U94 (pins 9,10,14). Also remove R100 and jumper at U94 (pins 9,10,14).

The DA disable input is not a serial signal, but is part of the RS-232 option as noted in the DA pin header. DA is taken possibly to micro supply (blank (middle)), if RS-232 is not used. U94 (pins 9,10,14) and a wire jumper from U94 pins 10 to 14. This will disable these inputs to U2.

Diodes D1 to D4 are for an external HV power transformer used in place of the switchmode power supply. This is no longer supported. See Page 3 of schematic.

WT must be jumpered

PT. Zetalink Technology Indonesia (Ltd.)
Yogyakarta, Indonesia
<http://www.zetalink.biz>
info@zetalink.biz

Microcontroller, power supply, options, etc.
Revision 1.5 22 July 2003
© Copyright 2003 Zetalink Technology (Ltd.)

These components are only loaded for the reversed or normal mounting option. For the normal mounting option, the components above the solid side of the board project above the solid side of the board. Also load jumpers X1 to X11 and W1-W12. Jumper W1-W12 and the other parts in the orange shaded area are not loaded.

optional decimal point

These components are loaded for normal nixie orientation, projecting above the PCB on the same side as all other components. Jumpers W1 to W12 are also part of this option. This is the default mounting position.

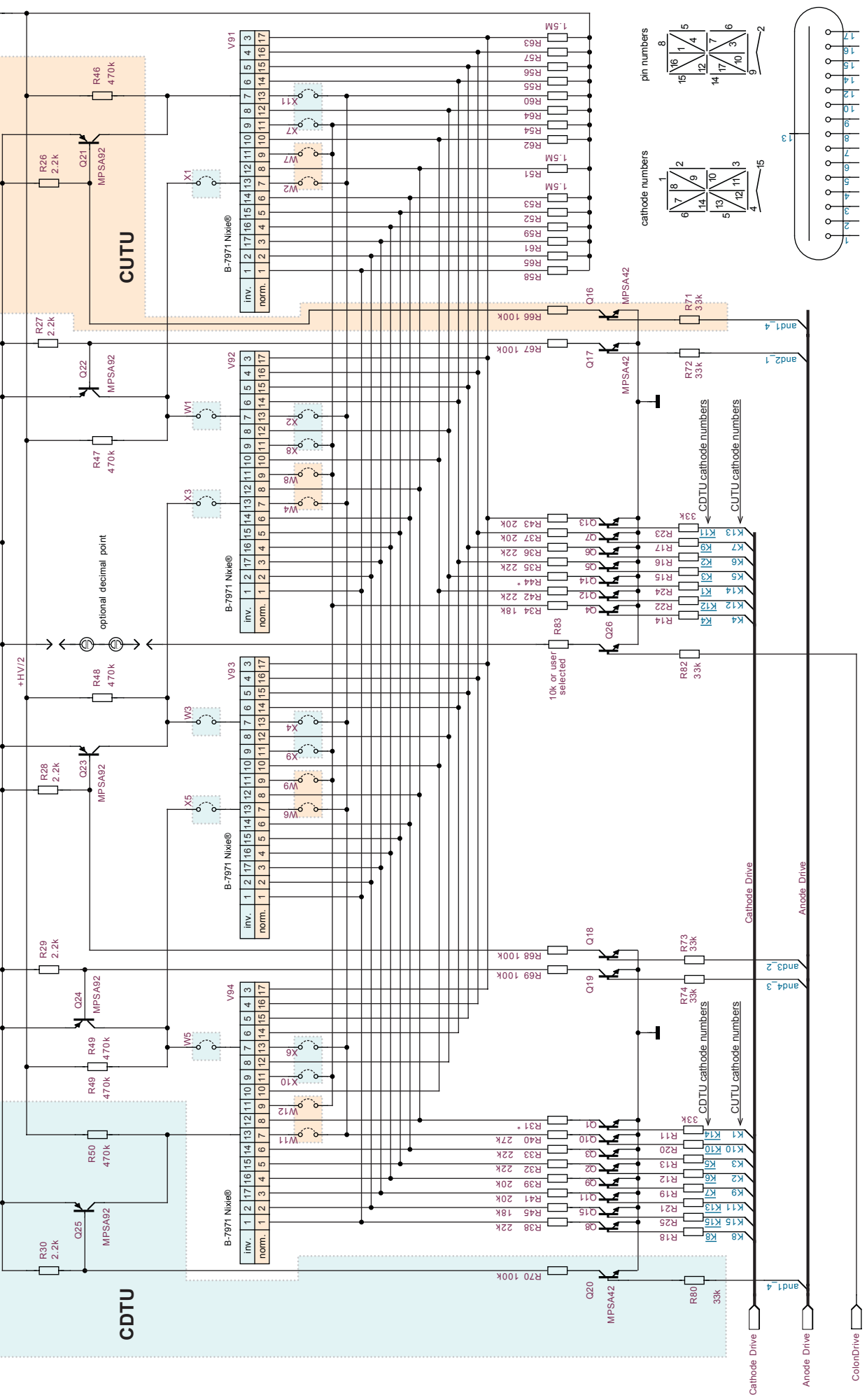

For normal B-7971 mounting on component side (CUTU), these parts are not installed: R30, R50, R70, R80, Q20, Q25, and all X-numbered jumpers.
 For reverse side mounting (CDTU), these parts are not installed: R26, R46, R66, R71, Q16, R66, R71, Q16, Q21, and W1 to W11.

Nixie Multiplex Drivers.

PT. Zetalink Technology Indonesia (Ltd.)
 Yogyakarta, Indonesia
<http://www.zetalink.biz>
info@zetalink.biz

Revision 1.5 22 July 2003
 © Copyright 2003 Zetalink Technology (Ltd.)

Power Supply connection

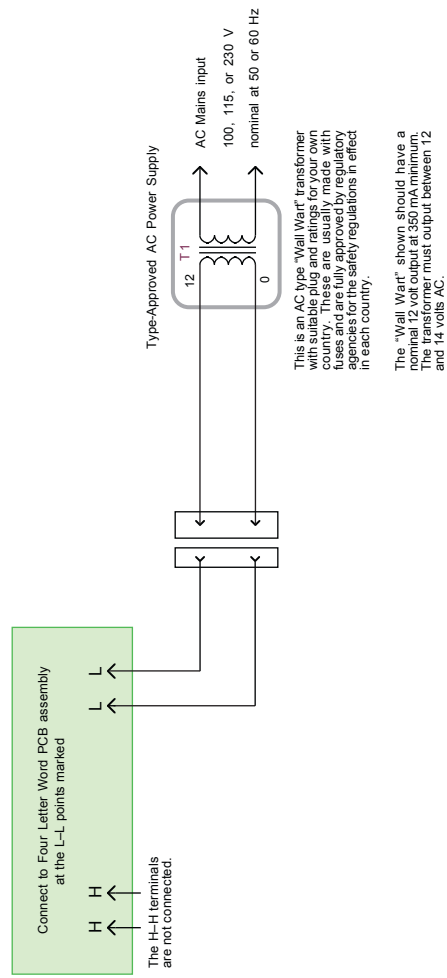

PT. Zetalink Technology Indonesia (Ltd.)
Yogyakarta, Indonesia
<http://www.zetalink.biz>
info@zetalink.biz

Revision 1.4 33 July 2003
© Copyright 2003 Zetalink Technology (Ltd.)